

Request For Quotation

Order the parts you need from our real-time inventory database. Simply complete a request for quotation form with your part information and a sales representative will respond to you with price and availability.

[Request For Quotation](#)

Your free datasheet starts on the next page.

More datasheets and data books are available from our homepage: <http://www.datasheetarchive.com>

DATA SHEET

TDA8395 SECAM decoder

Preliminary specification
File under Integrated Circuits, IC02

October 1991

SECAM decoder**TDA8395****FEATURES**

- Fully integrated filters
- Alignment free
- For use with baseband delay

GENERAL DESCRIPTION

The TDA8395 is a self-calibrating, fully integrated SECAM decoder. The IC should preferably be used in conjunction with the PAL/NTSC decoder TDA8362 or TDA8366 and with the switched capacitor baseband delay circuit TDA4660. The IC incorporates HF and LF filters, a demodulator and an identification circuit (luminance is not processed in this IC). The IC needs no adjustments and very few external components are required. A highly stable reference frequency is required for calibration and a two-level sandcastle pulse for blanking and burst gating.

QUICK REFERENCE DATA

SYMBOL	PARAMETER	MIN.	TYP.	MAX.	UNIT
V_P	positive supply voltage; pin 3	7.2	–	8.8	V
P_{tot}	total power dissipation	–	–	220	mW
$V_{16(p-p)}$	composite video input voltage (peak-to-peak value); pin 16	–	1.0	1.5	V
$V_{O(p-p)}$	–(R–Y) output voltage amplitude (peak-to-peak value); pin 9	–	1.05	–	V
$V_{O(p-p)}$	–(B–Y) output voltage amplitude (peak-to-peak value); pin 10	–	1.33	–	V

ORDERING INFORMATION

EXTENDED TYPE NUMBER	PACKAGE			
	PINS	PIN POSITION	MATERIAL	CODE
TDA8395	16	DIL	plastic	SOT38GE1 ⁽¹⁾

Note

1. SOT38-1; 1996 December 3.

SECAM decoder

TDA8395

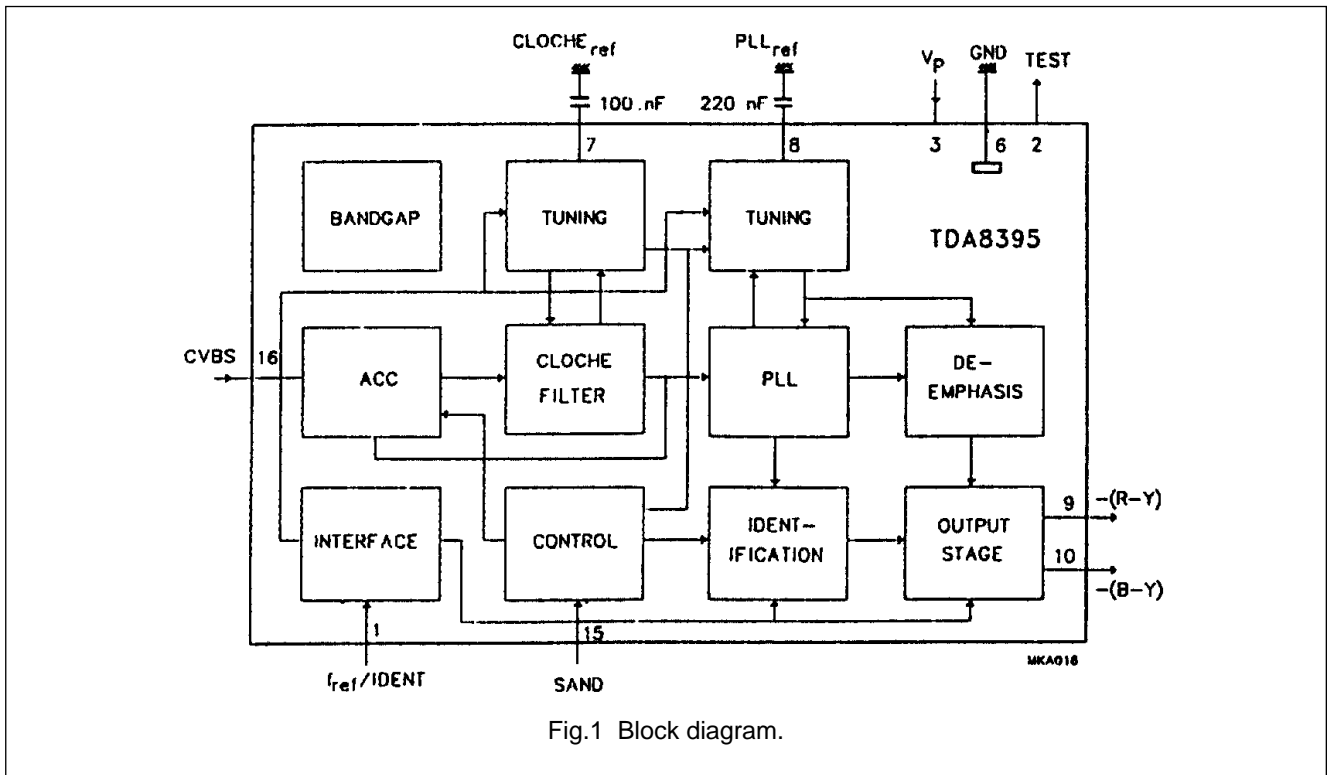

Fig.1 Block diagram.

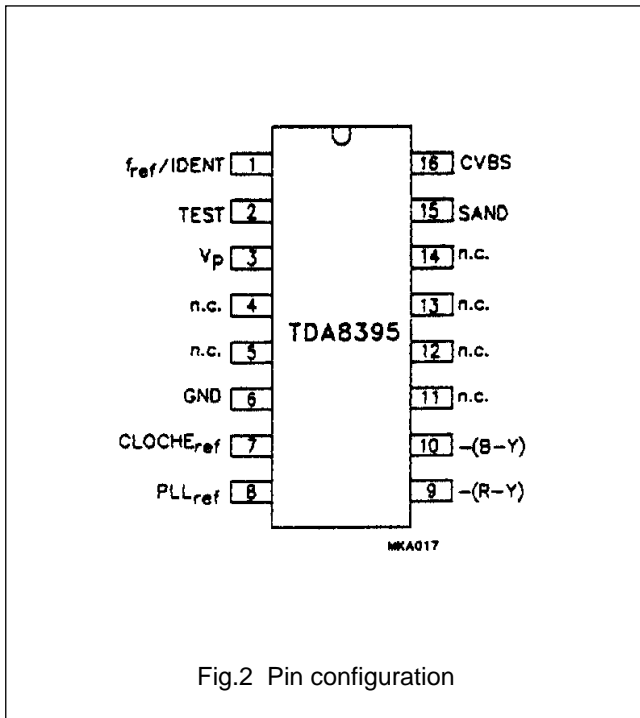

Fig.2 Pin configuration

PINNING

SYMBOL	PIN	DESCRIPTION
$f_{ref}/IDENT$	1	reference frequency input/identification input
TEST	2	test output
V_p	3	positive supply voltage
n.c.	4	not connected
n.c.	5	not connected
GND	6	ground
$CLOCHE_{ref}$	7	Cloche reference filter
PLL_{ref}	8	PLL reference
$-(R-Y)$	9	$-(R-Y)$ output
$-(B-Y)$	10	$-(B-Y)$ output
n.c.	11	not connected
n.c.	12	not connected
n.c.	13	not connected
n.c.	14	not connected
SAND	15	sandcastle pulse input
CVBS	16	video (chrominance) input

SECAM decoder

TDA8395

FUNCTIONAL DESCRIPTION

The TDA8395 is a self-calibrating SECAM decoder designed for use with a baseband delay circuit.

During frame retrace a 4.433619 MHz reference frequency is used to calibrate the filters and the demodulator. The reference frequency should be very stable during this period.

The Cloche filter is a gyrator-capacitor type filter the resonance frequency of which is controlled during the calibration period and offset during scan; this ensures the correct frequency during calibration.

The demodulator is a Phase-Locked Loop (PLL) type demodulator which uses the frequency reference and the bandgap reference to force the PLL to the required demodulation characteristic.

The low frequency de-emphasis is matched to the PLL and is controlled by the tuning voltage of the PLL.

A digital identification circuit scans the incoming signal for SECAM (only line-identification is implemented). The identification circuit needs to communicate with the TDA8362 to guarantee that the output signal from the decoder is only available when no PAL signal has been identified. If a SECAM signal is decoded a request for

colour-on is transmitted to pin 1 (current is sunk). If the signal request is granted (i.e. pin 1 is HIGH therefore no PAL) the colour difference outputs $-(B-Y)$ and $-(R-Y)$ from the TDA8362 are high impedance and the output signals from the TDA8395 are switched ON.

If no SECAM signal is decoded during a two-frame period the demodulator will be initialized before another attempt is made also during a two-frame period. The CD outputs will be blanked or high-impedance depending on the logic level at pin 1.

A two-level sandcastle pulse generates the required blanking periods and, also, clocks the digital identification pulse on the falling edge of the burst gate pulse. To enable the calibration period to be defined the vertical retrace is discriminated from the horizontal retrace, this is achieved by measuring the width of the blanking period.

LIMITING VALUES

In accordance with the Absolute Maximum System (IEC 134)

SYMBOL	PARAMETER	MIN.	MAX.	UNIT
V_P	positive supply voltage	–	8.8	V
T_{stg}	storage temperature range	–25	+150	°C
T_{amb}	operating ambient temperature range	–25	+70	°C

SECAM decoder

TDA8395

CHARACTERISTICS $V_P = 8.0\text{ V}$; $T_{amb} = 25\text{ °C}$; unless otherwise specified

SYMBOL	PARAMETER	CONDITIONS	MIN.	TYP.	MAX.	UNIT
Supply (pin 3)						
V_P	positive supply voltage		7.2	8.0	8.8	V
I_P	supply current		–	18	25	mA
P_{tot}	total power dissipation		–	144	220	mW
CVBS input (pin 16)						
$V_{16(p-p)}$	composite video input voltage (peak-to-peak value)		–	1.0	1.5	V
$V_{16(p-p)}$	chrominance input voltage (peak-to-peak value)	note 1	15	–	300	mV
Z_I	input impedance	note 2	–	15	–	k Ω
CLOCHE (pin 7)						
V_{tc}	tuning voltage		2.5	3.5	4.5	V
f_0	resonance frequency	note 3	4.266	4.286	4.306	MHz
B	bandwidth		241	268	295	kHz
Demodulator						
V_{td}	tuning voltage; pin 8		3.5	–	4.8	V
$V_{O(p-p)}$	output voltage amplitude (peak-to-peak value); pin 9	100/75 colour bar	0.97	1.05	1.13	V
$V_{O(p-p)}$	output voltage amplitude (peak-to-peak value); pin 10	100/75 colour bar	1.23	1.33	1.43	V
NLE	non-linearity error	100/75 colour bar; note 4	–	–	3	%
$-(B-Y)/(R-Y)$	ratio of $-(B-Y)$ and $-(R-Y)$		1.23	1.27	1.32	
$f_{be-(R-Y)}$	black-level error $-(R-Y)$	note 5	–	–	5	kHz
$f_{be-(B-Y)}$	black-level error $-(B-Y)$	note 5	–	–	7	kHz
V_O	output voltage level during blanking		–	2.8	–	V
B_O	output bandwidth		–	1.3	–	MHz
S/N	signal-to-noise ratio	note 6	40	–	–	dB
f_p	pole-frequency LF de-emphasis		77	85	93	kHz
f_p/f_0	ratio of pole and zero frequency		–	3	–	
$V_{rh(p-p)}$	residual harmonic voltage (peak-to-peak value)		–	–	10	mV
$Z_{O(e)}$	output impedance SECAM enabled	pin 1 HIGH	–	–	600	Ω
$Z_{O(d)}$	output impedance SECAM disabled	pin 1 LOW	1	–	–	M Ω

SECAM decoder

TDA8395

SYMBOL	PARAMETER	CONDITIONS	MIN.	TYP.	MAX.	UNIT
Sandcastle pulse						
V_{bl}	blanking detection level		1.0	1.25	1.5	V
V_{bg}	burst gate detection level		3.5	3.85	4.2	V
t_f	falling edge of burst gate to start sync		8.5	9.0	9.5	μ s
Reference/communication						
f_{ref}	reference frequency	note 7	–	4.4336	–	MHz
$V_{ref(p-p)}$	reference voltage amplitude (peak-to-peak value)		0.20	–	0.50	V
V_{ed}	SECAM enable detection level; pin 1		–	2.8	3.3	V
V_{dd}	SECAM disabled detection level; pin 1	note 8	1.5	2.0	–	V
I_s	sink current at SECAM identification; pin 1	note 9	–	150	–	μ A
Identification						
t_i	identification time		–	4	–	frames
H	colour on/off hysteresis		3	–	–	dB

Notes to the characteristics

1. If measured in the burst-period of a blue line.
2. The video input is AC-coupled.
3. During scan.
4. Measured as $100\% \times (|V_u| - |V_l|) / (|V_u| + |V_l|)$; see Fig.3.
5. Converted to input frequency error.
6. Defined as the ratio between the peak-to-peak value of the B–Y component of the demodulated 100/75 colour bar and the peak-to-peak value of the noise.
7. The reference should be stable during frame blanking.
8. The SECAM enable and disable timing should preferably be at the end of the frame blanking.
9. The externally supplied voltage should exceed 0.5 V.

SECAM decoder

TDA8395

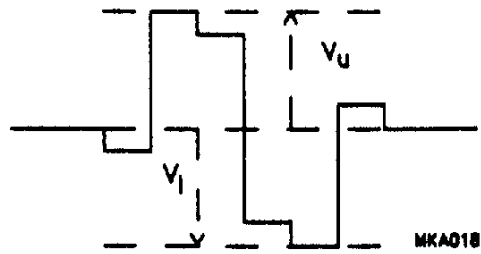

Fig.3 Non-linearity definition.

TIMING

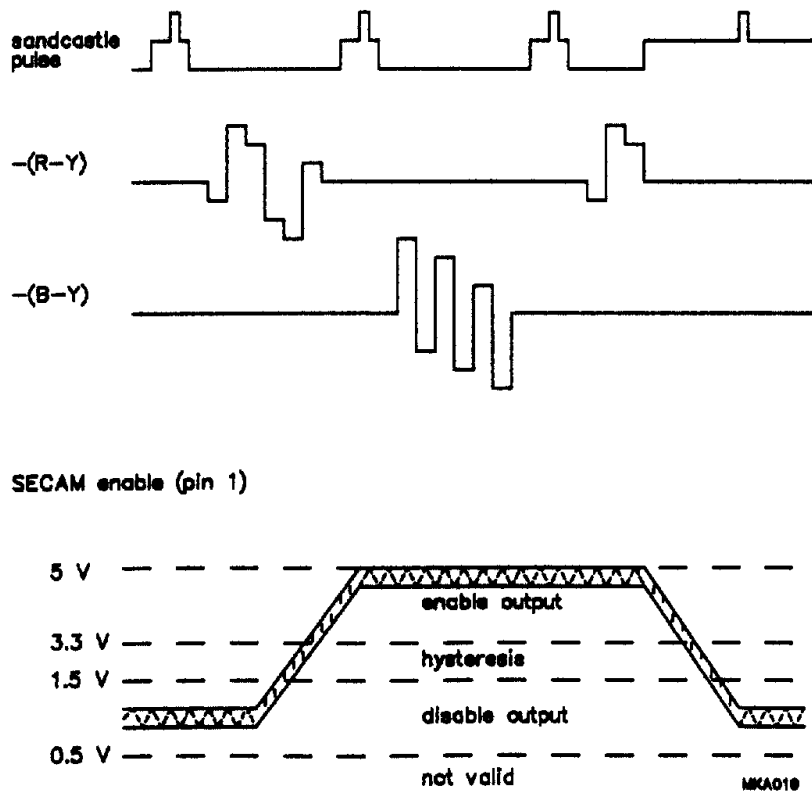

Fig.4 Timing waveforms.

SECAM decoder**TDA8395**

APPLICATION INFORMATION

The leakage current at pin 8 should be well below 20 nA to meet the specification of the black levels ($C8 = 220$ nF).
The leakage current at pin 7 should be well below 60 nA to meet the specification of the Cloche resonance frequency ($C7 = 100$ nF).

The capacitors C7 and C8 should be connected to the ground pin as close as possible to the package. If not, this can result in a black level error for both channels.

TEST INFORMATION

The performance of the Cloche filter can be measured at pin 2. The use of a FET-probe is advised for low capacitive loading.

SECAM decoder

TDA8395

PACKAGE OUTLINE

DIP16: plastic dual in-line package; 16 leads (300 mil); long body

SOT38-1

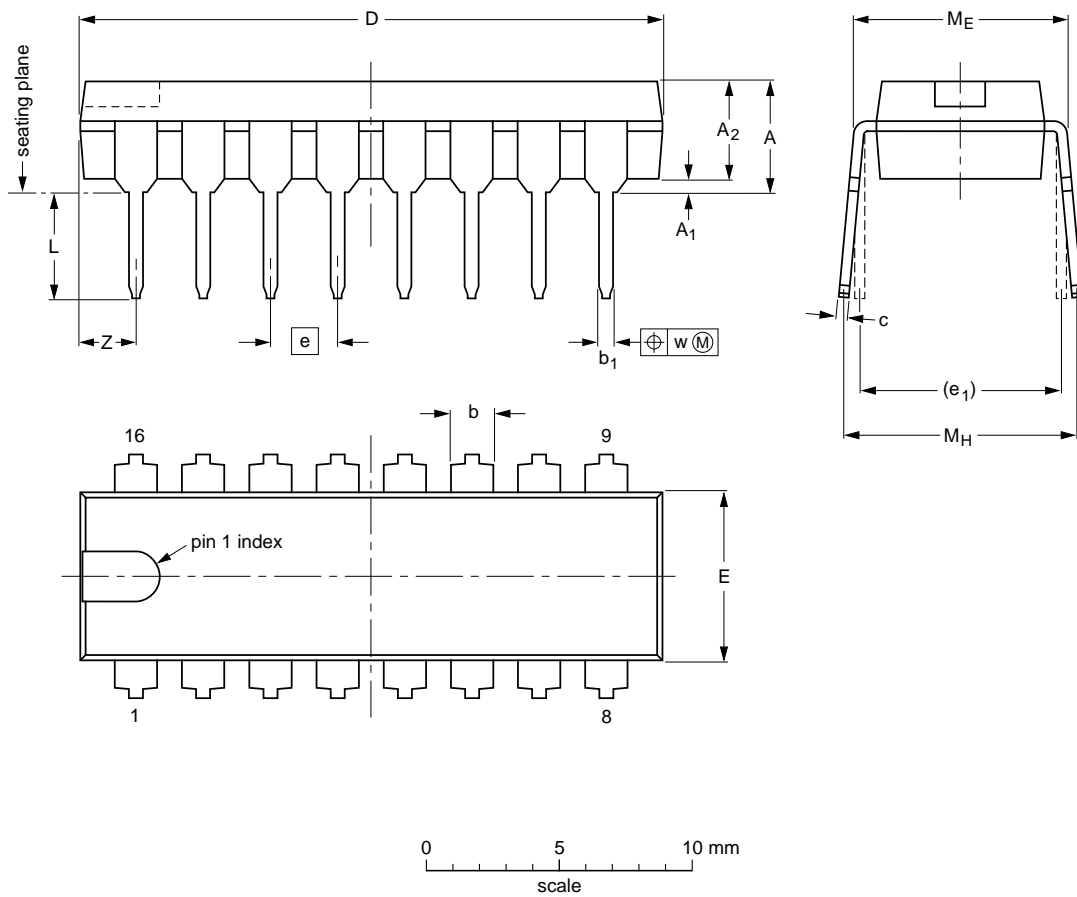

DIMENSIONS (inch dimensions are derived from the original mm dimensions)

UNIT	A max.	A ₁ min.	A ₂ max.	b	b ₁	c	D ⁽¹⁾	E ⁽¹⁾	e	e ₁	L	M _E	M _H	w	Z ⁽¹⁾ max.
mm	4.7	0.51	3.7	1.40 1.14	0.53 0.38	0.32 0.23	21.8 21.4	6.48 6.20	2.54	7.62	3.9 3.4	8.25 7.80	9.5 8.3	0.254	2.2
inches	0.19	0.020	0.15	0.055 0.045	0.021 0.015	0.013 0.009	0.86 0.84	0.26 0.24	0.10	0.30	0.15 0.13	0.32 0.31	0.37 0.33	0.01	0.087

Note

1. Plastic or metal protrusions of 0.25 mm maximum per side are not included.

OUTLINE VERSION	REFERENCES				EUROPEAN PROJECTION	ISSUE DATE
	IEC	JEDEC	EIAJ			
SOT38-1	050G09	MO-001AE				92-10-02 95-01-19

SECAM decoder

TDA8395

SOLDERING**Introduction**

There is no soldering method that is ideal for all IC packages. Wave soldering is often preferred when through-hole and surface mounted components are mixed on one printed-circuit board. However, wave soldering is not always suitable for surface mounted ICs, or for printed-circuits with high population densities. In these situations reflow soldering is often used.

This text gives a very brief insight to a complex technology. A more in-depth account of soldering ICs can be found in our "IC Package Databook" (order code 9398 652 90011).

Soldering by dipping or by wave

The maximum permissible temperature of the solder is 260 °C; solder at this temperature must not be in contact with the joint for more than 5 seconds. The total contact time of successive solder waves must not exceed 5 seconds.

The device may be mounted up to the seating plane, but the temperature of the plastic body must not exceed the specified maximum storage temperature ($T_{stg\ max}$). If the printed-circuit board has been pre-heated, forced cooling may be necessary immediately after soldering to keep the temperature within the permissible limit.

Repairing soldered joints

Apply a low voltage soldering iron (less than 24 V) to the lead(s) of the package, below the seating plane or not more than 2 mm above it. If the temperature of the soldering iron bit is less than 300 °C it may remain in contact for up to 10 seconds. If the bit temperature is between 300 and 400 °C, contact may be up to 5 seconds.

DEFINITIONS

Data sheet status	
Objective specification	This data sheet contains target or goal specifications for product development.
Preliminary specification	This data sheet contains preliminary data; supplementary data may be published later.
Product specification	This data sheet contains final product specifications.
Limiting values	
Limiting values given are in accordance with the Absolute Maximum Rating System (IEC 134). Stress above one or more of the limiting values may cause permanent damage to the device. These are stress ratings only and operation of the device at these or at any other conditions above those given in the Characteristics sections of the specification is not implied. Exposure to limiting values for extended periods may affect device reliability.	
Application information	
Where application information is given, it is advisory and does not form part of the specification.	

LIFE SUPPORT APPLICATIONS

These products are not designed for use in life support appliances, devices, or systems where malfunction of these products can reasonably be expected to result in personal injury. Philips customers using or selling these products for use in such applications do so at their own risk and agree to fully indemnify Philips for any damages resulting from such improper use or sale.